

Direct Drive Turntable
- AT-LP5 with Analog and USB Outputs -

直驅式唱盤
-AT-LP5, 含類比與USB輸出-

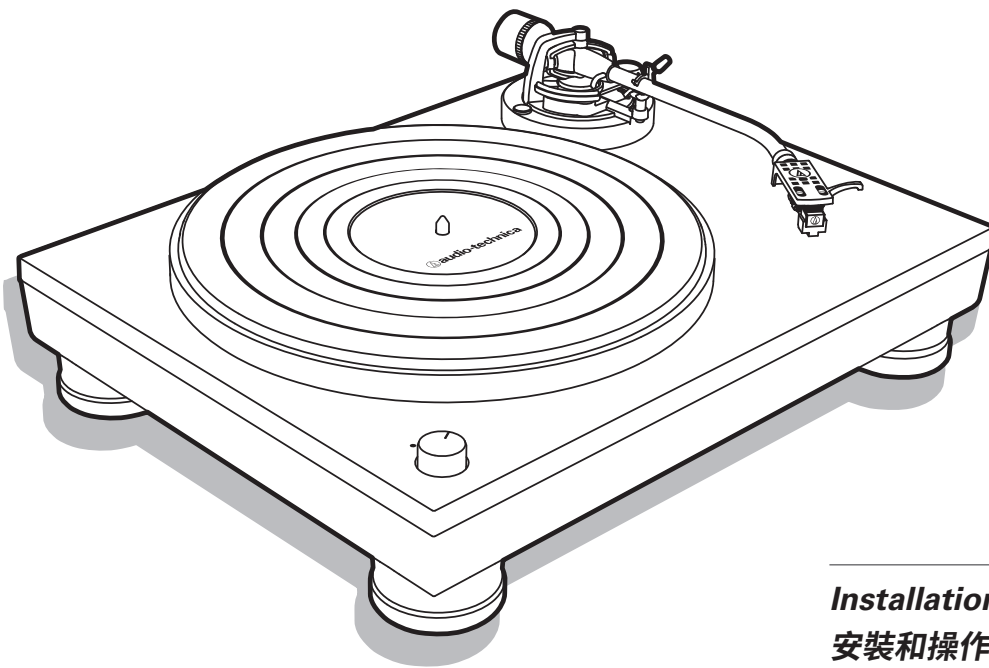

Installation and Operation Pages 2-7
安裝和操作頁面 8-13

Direct Drive Turntable with Analog and USB Outputs

Introduction

Thank you for purchasing this AT-LP5 Direct Drive Analog and USB Turntable. Audio-Technica brings its legendary quality and audio fidelity to the authentic home-use turntable. In the box, you'll find everything you need to transfer your classic LP collection to digital files:

Audio-Technica's AT-LP5 stereo turntable, complete with USB output that allows direct connection to your computer; Audacity recording software for MAC or PC; USB cable and an RCA / RCA stereo adapter cable. This turntable also includes an integral dual-magnet Audio-Technica exclusive AT95EX cartridge, sophisticated J-shaped tonearm, and offers a built-in switchable phono/line pre-amplifier that provides connection to a stereo system equipped with either phono or line-level inputs.

The AT-LP5 Direct Drive Turntable has the following features:

- Audio-Technica AT95EX Dual Moving Magnet stereo cartridge with replaceable stylus
- Exclusive Audio-Technica AT-HS10 Lightweight Headshell
- Cast aluminium record platter with rubber mat
- Selectable internal stereo phono pre-amplifier
- Stereo RCA analog outputs
- J-shaped tonearm assembly with:
 - Adjustable counterweight
 - Anti-skate adjustment
 - Tonearm lift with hydraulic action and lift lever
 - Tonearm rest with locking mechanism
- USB output—no special drivers required for direct connection to your computer
- Direct drive high-torque motor
- Selectable 33/45 RPM speeds
- Adjustable feet for leveling
- Hinge mounting points with screws for optional removable hinged dust cover

To assure maximum satisfaction from this product, please read the information and follow the instructions presented in this manual. Please keep the manual in an accessible location for future reference. We suggest that you save all packaging materials for possible future storage, moving, or shipping.

Caution: To avoid stylus damage, make certain the included stylus guard is in place whenever the turntable is being installed, moved, or cleaned.

Safety instructions

1. Read these instructions.
2. Keep these instructions.
3. Follow all warnings.
4. Follow all instructions.
5. Do not use this apparatus near water.
6. Clean only with a dry cloth.
7. Do not block any of the ventilation openings. Install in accordance with the manufacturer's instructions.
8. Do not install near any heat sources such as radiators, heat registers, stoves, or other apparatus (including amplifiers) that produce heat.
9. Do not defeat the safety purpose of the polarized or grounding plug. A polarized plug has two blades with one wider than the other. A grounding plug has two blades and a third grounding prong. The wide blade or the third prong is provided for your safety. If the provided plug does not fit into your outlet, consult an electrician for replacement of the obsolete outlet.
10. Protect the power cord from being walked on or pinched particularly at plugs, convenience receptacles, and the point where they exit from the apparatus.
11. Only use attachments/accessories specified by the manufacturer.
12. Use only with a cart, stand, tripod, bracket or table specified by the manufacturer, or sold with the apparatus. When a cart is used, use caution when moving the cart/apparatus combination to avoid injury from tip-over.
13. Unplug this apparatus during lightning storms or when unused for long periods of time.



14. Refer all servicing to qualified service personnel. Servicing is required when the apparatus has been damaged in any way, such as power-supply cord or plug is damaged, liquid has been spilled or objects have fallen into the apparatus, the apparatus has been exposed to rain or moisture, does not operate normally, or has been dropped.
15. Where a mains plug is used as the disconnect device, the disconnect device shall remain readily operable.
16. Please keep the unit in a good ventilation environment.
17. Apparatus shall not be exposed to dripping or splashing and no objects filled with liquids, such as vases, shall be placed on apparatus.

Warning: To reduce the risk of fire or electric shock, do not expose this apparatus to rain or moisture. The apparatus shall not be exposed to dripping or splashing and that no objects filled with liquids, such as vases, shall be placed on the apparatus.



CAUTION
RISK OF ELECTRIC SHOCK
DO NOT OPEN



Caution: To reduce the risk of fire or electric shock, do not expose this apparatus to rain or moisture. The apparatus shall not be exposed to dripping or splashing, and no objects filled with liquids, such as vases, shall be placed on the apparatus.



The lightning flash with arrowhead symbol within the equilateral triangle is intended to alert the users to the presence of uninsulated "dangerous voltage" within the product's enclosure that may be of sufficient magnitude to constitute a risk of electric shock.



The exclamation point within the equilateral triangle is intended to alert the user to the presence of important operation and maintenance (servicing) instructions in the literature accompanying this appliance.

Caution: To prevent electric shock, do not use this polarized plug with an extension cord, receptacle or other outlet unless the blades can be fully inserted to prevent blade exposure.

Main Features

Figure 1

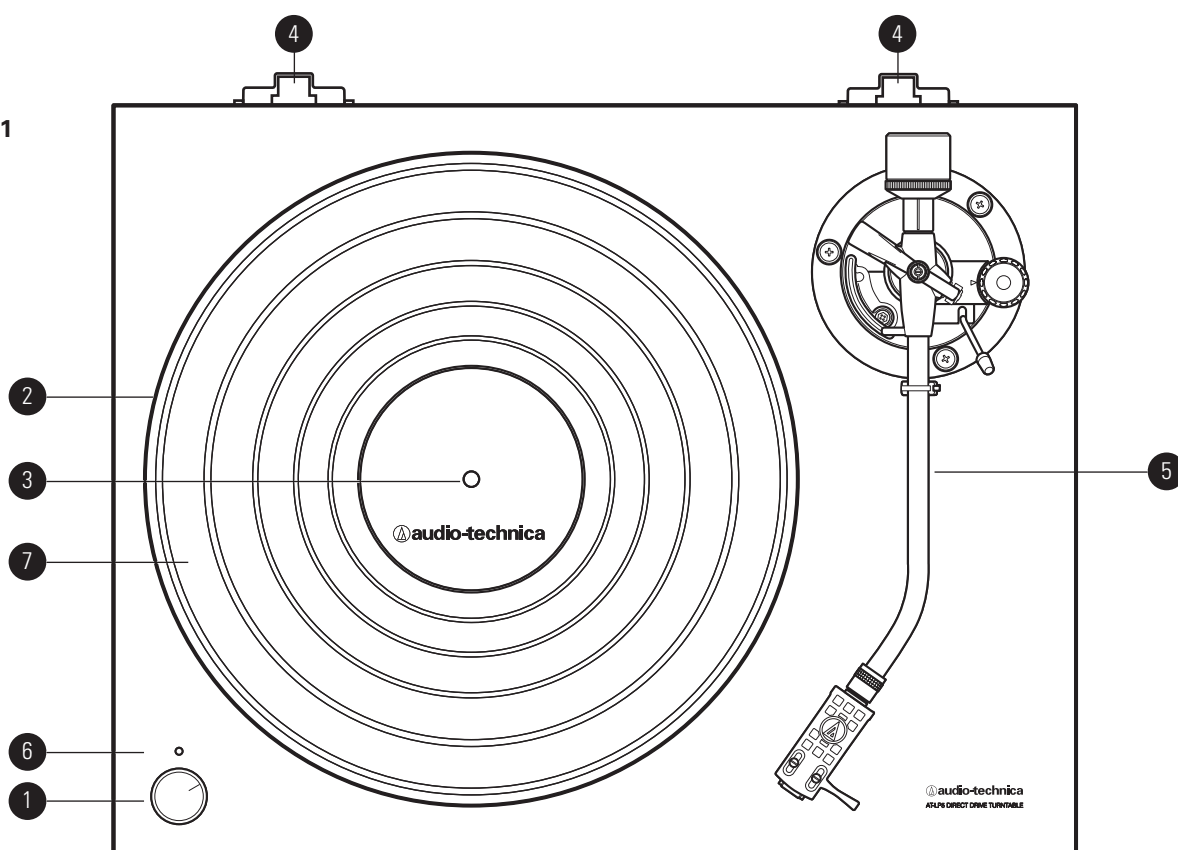

- ❶ 33 / STOP / 45 STANDBY AND SPEED SELECTOR KNOB
Selects 33 or 45 RPM platter speed and starts/stops the motor.
- ❷ PLATTER
Cast aluminium platter mounts directly to center spindle/motor shaft.
- ❸ CENTER SPINDLE
Precision-machined platter mount on motor shaft.
- ❹ DUST COVER HINGE HOLDERS
Attachment points for removable hinged dust cover.
- ❺ TONEARM ASSEMBLY
Refer to Figure 2 on page 4 for details.
- ❻ ON/OFF INDICATOR LIGHT
- ❼ RUBBER MAT

Tonearm Assembly Diagram

Figure 2

- 8 HEADSHELL and CARTRIDGE
Exclusively high performance AT95EX cartridge is mounted with headshell. AT-HS10 light weight headshell suits perfectly with J-shaped tonearm.
- 9 HEADSHELL LOCKING RING
Rotate counter-clockwise (to the left) to draw the inserted headshell firmly into its seated, locked position. Rotate the ring a full turn to the right to permit removal of the headshell.
- 10 TONEARM
J-shaped tonearm geometry reduces tracking error.
- 11 TONEARM LIFT
Elevates tonearm above record surface.
- 12 TONEARM REST WITH LOCKING CLAMP
Locking clamp secures tonearm during transport.
- 13 TONEARM LIFT ADJUST SCREW
Used to set the amount of tonearm lift.
- 14 TONEARM LIFT CONTROL LEVER
Controls action of tonearm lift. (Note: Lift mechanism is hydraulically damped to slow tonearm descent.)
- 15 ANTI-SKATE CONTROL
Applies a small outward force to the tonearm, counteracting the tendency of the tonearm to move inward toward the center of the record when the record rotates.
- 16 COUNTERWEIGHT
Balances the tonearm and provides adjustment for proper downward tracking force on the stylus.

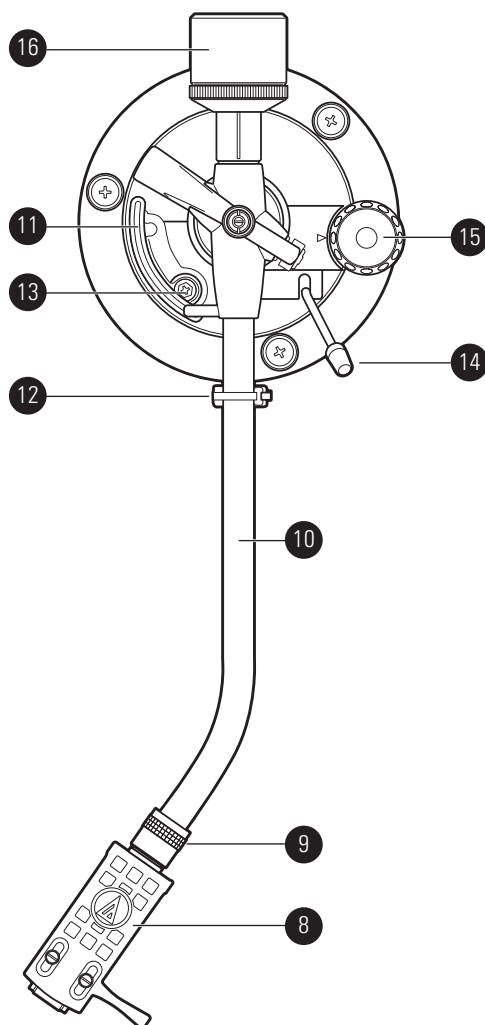

Rear View Diagram

Figure 3

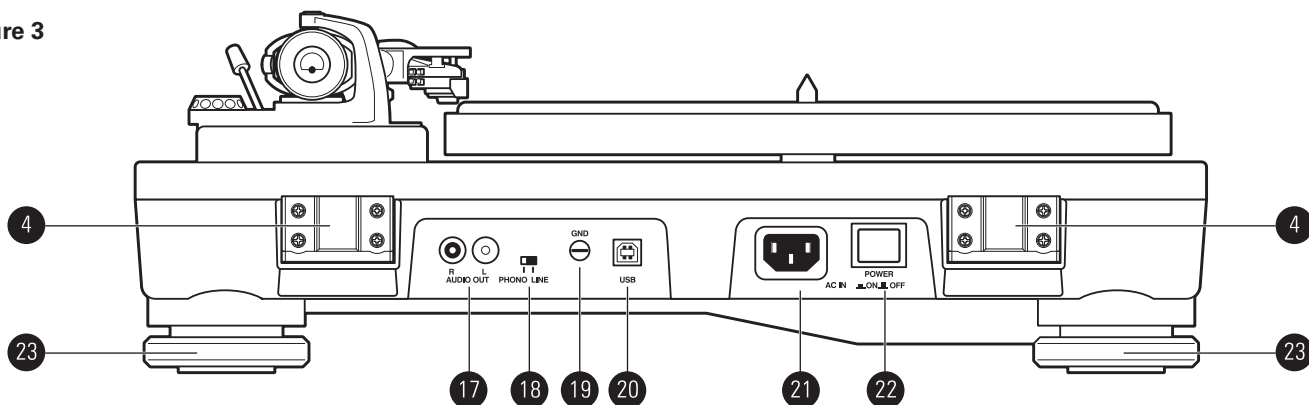

- 17 RCA STEREO ANALOG OUTPUT
Use these terminals to connect the RCA stereo cable with attached grounding to the phono input terminals or line input of your amplifier.
- 18 PRE-AMPLIFIER SELECTOR SWITCH
Allows the internal stereo phono pre-amplifier to be bypassed when the turntable is used with amplifiers having magnetic phono inputs.
- 19 GROUND TERMINAL
Use this terminal to connect the grounding line of the RCA cables to the ground terminal of the amplifier.
- 20 USB OUTPUT
Use this output to connect your turntable to the USB input of your computer.
- 21 AC INLET
To connect the power cord supplied with the unit.
- 22 ON/OFF SWITCH
Use this switch to switch on / off power to the turntable.
- 23 ADJUSTABLE FEET FOR LEVELING
Rotate feet to adjust leveling.

Initial Setup

Unpacking

Carefully unpack the turntable and verify that the following parts are included and intact:

- Rubber mat
- Dust cover (above the turntable)
- Platter (under the turntable)
- Counterweight (accessory section)
- AT-HS10 headshell with pre-mounted AT95EX Dual Moving Magnet stereo cartridge (accessory section)
- Exclusive AT-HS10 Lightweight Headshell
- Power cable
- USB cable
- Dual RCA male to dual RCA male cable with grounding line
- Audacity software (CD)

WE RECOMMEND THAT YOU SAVE ALL PACKAGING MATERIALS FOR POSSIBLE FUTURE STORAGE, MOVING OR SHIPPING.

Assembling the Turntable

The AT-LP5 requires some assembly before first use.

IMPORTANT: Do not connect the AC power cable until assembly is complete.

Setting the Pre-amplifier Selector Switch

For increased flexibility of use, this turntable has an internal stereo phono pre-amplifier. The pre-amplifier selector switch located in the rear panel of the turntable [See Figure 3, page 4, #18], selects the internal stereo pre-amplifier (LINE), or bypasses the pre-amplifier (PHONO OUT) for use with systems having specialized magnetic phono input sockets. The audio output cable's Red RCA-type plug is the Right channel; the White plug is the Left channel.

If the system you are using has a phono input, set the pre-amplifier selector switch to the PHONO position and connect the turntable's output cables to the phono inputs on your system, observing Red for Right channel and White for Left channel, in addition connect the grounding line attached to the stereo RCA / RCA cables to the ground terminals.

If your system does not have a magnetic phono input, set the pre-amplifier selector switch to LINE and connect the turntable's output to the Auxiliary (AUX) or other high-level inputs on your system, observing Red for Right channel and White for Left channel.

When using the turntable with a computer sound card, set the switch to LINE and connect the turntable's stereo output to the audio line input on the computer sound card. Note: An audio adapter (not included) may be required to interface the two RCA outputs (L + R) of the turntable to the computer sound card input.

Assembling the Tonearm

1. Remove the nylon tie used to secure the tonearm during shipment. Temporarily secure the tonearm in the tonearm rest with the locking clamp. [Figure 2, page 4, #12].
2. Attach the headshell/cartridge assembly by inserting it into the socket at the front of the tonearm [See Figure 4]. It is good practice to hold the headshell assembly by the left and right edges of the headshell to reduce the possibility of damaging the stylus or disrupting the cartridge wiring.

Figure 4 – Headshell with fitted cartridge

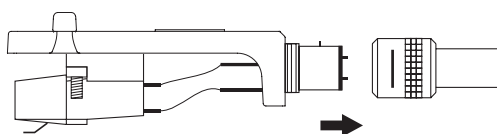

3. While holding the headshell in position, rotate the headshell locking ring counter-clockwise (to the left). As the ring turns, it pulls the headshell into its seated position (rotate the ring a full turn to the right to permit removal of the headshell).
4. With the black dial toward the front, use a screwing motion to attach the counterweight to the arm extending back from the tonearm pivot [Figure 2, page 4, #16]; the counterweight will engage the spiral groove in the rear arm section and move forward.

Assembling the Turntable Platter and Rubber Mat

1. Carefully place the turntable platter on the center spindle, making certain the platter is fully seated on the spindle.
2. Place the rubber mat on top of the platter.

Assembling the Dust Cover

1. Insert the T-shaped ends of the dust cover hinges into the two hinge receptacles located at the back of the turntable housing. When properly installed, the flat part of the cover hinges should be facing away from the turntable housing at about a 45° angle.
2. Holding the dust cover over the turntable, carefully guide the cover hinges into the two slots molded into the rear of the dust cover. The springs in the hinges allow the cover to be held open at about a 45° angle if desired. (Note: There is only one "open" position; the hinges do NOT permit the cover to stand "straight up.")
3. To remove the dust cover from the turntable, gently disengage the hinges from the slots in the cover. This is usually easier when the cover is in the "closed" position. Slowly and carefully lift straight up until the cover is clear of the unit. The hinges may then be removed from the turntable base, if desired.

Setting Tonearm Balance and Tracking Force

To ensure the cartridge tracks properly in a record, the tonearm balance and tracking force must be carefully set to the cartridge manufacturer's specifications. Failure to properly set up the tonearm assembly can cause damage to the cartridge stylus and/or records.

Note: Once the stylus protective cover has been removed and the tonearm locking clamp has been released, **take extreme care not to damage the stylus**. Do not allow it to drag or scrape across the rubber mat nor the record.

Tonearm Setup

1. Set the anti-skate adjustment to "0". [Figure 2, page 4, #15].
2. Remove the clear protective stylus cover, carefully sliding it **straight forward**, off the front of the cartridge.
3. Continuing to gently hold the headshell to stabilize the tonearm, release the tonearm locking clamp. At this point, the tonearm is unbalanced and free to swing.
4. Continuing to gently hold the headshell, carefully rotate the counterweight until the tonearm is horizontally balanced and hovers freely just above the platter without touching the cartridge on the platter surface.
5. Lock the tonearm back into the tonearm rest.
6. While holding the counterweight steady, and without any rotation, carefully rotate only the black stylus force gauge ring (which turns independently of the counterweight) until the "0" on the gauge ring lines up with the centerline marked along the top of the rear arm.
7. Refer to the cartridge manufacturer's specifications for recommended tracking force. Rotate the entire counter-weight counterclockwise without touching the black gauge ring, moving the counterweight forward, until the desired value on gauge ring lines up with the centerline marked on the rear arm. Refer to the specifications section for tracking force value for the cartridge that shipped with the turntable, typically 2 g for the AT95EX.

Initial Setup (continued)

Setting Anti-skate

A small outward “anti-skating” force can be applied to the tonearm to compensate for the “skating” force that pulls the arm toward the center of the record when rotating. For best performance during normal turntable use, set the anti-skate control knob [Figure 2, page 4, #15] to the same setting as the tracking force dial. Refer to the specifications section for tracking force value of the cartridge that shipped with the turntable.

Analog Audio Connections

Connect the audio output cable to the appropriate input sockets on your amplifier, receiver, powered speakers, soundcard or other device based on the setting of the pre-amplifier selector switch.

Digital Audio USB Connection to Computers with USB Input

The USB cable (included) connects your AT-LP5 turntable to your computer without need for special drivers.

Your Audio-Technica AT-LP5 turntable is supplied with Audacity recording software for your convenience. Please note that other third-party software packages are also compatible with this turntable.

Audacity

Audacity is free software, distributed under the GNU General Public License (GPL). More information and open source code is on the included Audacity CD and on the Audacity website :
<http://audacity.sourceforge.net>

*** When using USB output always set the AT-LP5 turntable's Pre-amplifier Selector Switch to the "LINE" position (switch is located on the back of the turntable).**

Finally, after all audio connections are made, attach the included AC power cord to the turntable. Then connect the power cord's plug to a convenient AC outlet.

For best results, do not install or operate this unit near conditions of heat, moisture, dust, or heavy vibrations.

Preparing to Play

1. Remove the stylus guard from the stylus assembly and unlock the tonearm rest if it is locked.
2. Place a record on the rubber mat, lining up its center hole with the center spindle. For 45 RPM records, place the 45 RPM adapter on the center spindle before placing the record on the platter.

Playing a Record

1. Press the power button on the rear panel to switch on.
2. Set the platter rotation speed (33/45) to match that of the record, the platter begins to rotate.
3. Raise the tonearm by lifting the tonearm lift control lever to the UP position.
4. Position the tonearm over the desired location (groove) on the record.
5. Lower the tonearm by moving the tonearm lift control lever to the DOWN position. The tonearm descends slowly onto the record and play begins.

– or – (skipping 2 - 3 - 4)

Use the finger-lift on the headshell assembly to position the tonearm over the desired location on the record. Carefully lower the tonearm to the record surface.

Suspending or Ending Play

1. To suspend play, lift the tonearm with the tonearm lift control lever.
2. When play is finished, raise the tonearm lift control lever, move the tonearm to the rest position and secure the tonearm with the tonearm locking clamp.
3. Turn the speed selector to “Stop” to apply the brake and stop the platter rotation.
4. Press the power button on the rear panel to switch off.

Installing a new Cartridge

Mechanical Assembly

1. Unpack the cartridge and carefully remove its stylus assembly. Place the stylus assembly out of harm's way. Mount the new cartridge to the headshell assembly. Use the mounting hardware supplied with the new cartridge. Tighten the mounting screws until just snug. Replace the stylus assembly briefly to check for mechanical interference with the mounting hardware. The stylus assembly should click into place. Make certain the new cartridge is properly positioned in the headshell assembly per the manufacturer's instructions. Again remove the stylus assembly for safekeeping.

Electrical Connections

1. Four terminals at the rear of the cartridge are colour coded to match standard wiring in stereo tonearms. Connect the cartridge with the slip-on lugs provided on the headshell wiring. NEVER SOLDER TO CARTRIDGE TERMINALS! Heat applied to the terminals will damage the internal cartridge wiring.
2. Finally, gently push the stylus onto the cartridge body being careful not to damage the stylus. The stylus assembly should click into place. Replace the headshell assembly onto the tonearm taking care not to damage the stylus assembly.

(Note: After replacing the cartridge, reset the tonearm balance, stylus force and anti-skate based on the cartridge's specifications.)

Using a MC (moving coil cartridge)

1. Note that the built-in phono pre-amplifier has a 36 dB gain with an input impedance of 47k ohms and is intended to be used exclusively with moving magnet cartridges such as the supplied AT95EX. When using a moving coil cartridge it is essential to bypass the built in pre-amplifier section switch (Figure 3, page 4, #18) by setting to the phono position. In this case the turntable stereo phono output needs to be connected to an external phono pre-amplifier featuring MC (moving coil) inputs, in order to guarantee the proper gain and the proper impedance load necessary when using an MC cartridge (refer to the specifications of your MC cartridge).

Troubleshooting

Turntable operates but emits no sound or not enough sound.

1. Amplifier (system) controls are set incorrectly: wrong input selected, tape monitor on, speakers switched off, etc. Verify proper control settings.
2. Stylus is broken or missing. Check the stylus assembly and replace if necessary.
3. The stylus assembly may not be fully seated in the cartridge body. Check the cartridge and adjust if necessary.
4. The pre-amplifier selector switch of the AT-LP5 is set in the wrong position. Verify that it is set to the correct output to match amplifier input.
 - No sound/very weak sound: Phono Out setting into an Aux/Line input.
 - Very loud/distorted sound: Line Out setting into a Phono input.
5. The tracking force is set too heavy (stylus assembly is bottoming out on record). Set tracking force per cartridge manufacturer's recommendation.
6. Turntable is picking up excessive vibrations from floor, walls, or nearby speakers. Reduce vibrations or place turntable on sturdy/solid surface.

Turntable operates but stylus "skips" across record.

1. The stylus guard is still in place. Remove the stylus guard.
2. The tracking force is set too light. Set tracking force per cartridge manufacturer's recommendation.
3. The anti-skate control is set improperly. Verify anti-skate is set for same value as cartridge tracking force.

Record sounds too fast or too slow.

1. Turntable is set for wrong speed. Make proper speed selection for record type being played with platter speed selector.

Tips to avoid damage

- Do not touch the stylus tip with your fingers; avoid bumping the stylus on the turntable mat or a record's edge.
- Clean the stylus tip frequently, using a soft brush **and a back-to-front motion**.
- If you use a stylus cleaning fluid, use it **sparingly**.
- **Never** apply harsh chemicals or solvents to any part of the turntable system.
- Prior to moving the turntable, always unplug it from the AC outlet and **lock the tonearm on the tonearm rest**.

Specifications*

Turntable Specifications

| | |
|----------------------------|--|
| Type | 2-Speed, fully manual operation |
| Motor | DC motor |
| Drive method | Direct drive |
| Speeds | 33-1/3 RPM, 45 RPM |
| Turntable platter | Die-cast aluminium |
| Starting torque | >1.6 kgf.cm |
| Braking system | Electronic brake |
| Wow and flutter | < 0.2% WRMS (33 RPM) |
| Signal-to-noise ratio | > 50 dB |
| Outputs levels | |
| "PHONO" (Pre-amp bypassed) | 4 mV nominal at 1 kHz, 5 cm/sec |
| "LINE" (Pre-amp engaged) | 150 mV nominal at 1 kHz, 5 cm/sec |
| Phono Pre-amp gain | 36 dB nominal, RIAA equalized |
| USB function | |
| A/D, D/A | 16 bit 44.1 kHz or 48 kHz USB selectable |
| Computer interface | USB 2.0 Compliant Windows XP, Vista or MAC OSX |

Tonearm Specifications

| | |
|---|---------------------------------|
| Type | Static balance J-shaped tonearm |
| Effective length | 247 mm |
| Overhang | 17 mm |
| Maximum tracking error angle | Less than 2.5° |
| Stylus pressure adjustment range | 0 to 2.5 g |
| Applicable cartridge weight range (including headshell) | 15 to 20g |

Cartridge and Headshell Specifications

| | |
|-------------------------------|-------------------------------------|
| Cartridge Model | AT95EX |
| Cartridge Type | VM Design Stereo Dual Moving Magnet |
| Recommended load impedance | 47,000 Ohms |
| Output voltage | 4 mV (at 1 kHz, 5 cm/sec) |
| Stylus | 0.3 x 0.7 mil elliptical |
| Tracking force range | 1.5 to 2.5 g (standard 2 g) |
| Cartridge weight | (AT95Ex) 5.7 g |
| Headshell model | AT-HS10 |
| Headshell weight | 10 g |
| Headshell overhang adjustment | ± 5 mm |

General Specifications

| | |
|---------------------------|---|
| Power supply requirements | 230V AC, 50 Hz (Singapore) 110V AC, 60 Hz (Taiwan) |
| Power consumption | 6W |
| Dimensions | 450.0 mm (17.72") W x 352.0 mm (13.86") D x 157.0 mm (6.1") H |
| Weight | 8.5 kg (18.74 lbs) |
| Accessories included | AT95EX Dual Moving Magnet stereo cartridge with replaceable stylus; Exclusive AT-HS10 Lightweight Headshell; AC line cord; dual RCA (male) to dual RCA (male) stereo cable; 45 RPM adapter; USB cable; recording software |

Audacity :

| | |
|---------------------|---|
| System requirements | PC or Mac with an available USB port (USB 2.0 or higher) Mac running OS X 10.4 to 10.10 or PC running Windows (XP and above) |
| Installation | CD-R or CD-RW writer for burning CDs & software installation Includes Audacity software for PC & Mac users |

*Specifications are subject to change without notice.

直驅式唱盤，含類比與USB輸出

產品簡介

感謝您購買AT-LP5直驅式類比與USB唱盤。此家用唱盤將為您帶來Audio-Technica的經典品質與高傳真音效。您可在盒內找到可將您經典LP唱片轉為數位檔案所需的內容：

Audio-Technica的AT-LP5立體聲唱盤具備可直接連接到您電腦的USB輸出功能，並提供可在MAC或PC上使用的Audacity錄音軟體，以及提供USB連接線與RCA / RCA立體聲轉接器連接線。此唱盤還整合了Audio-Technica獨家的AT95EX dual-magnet唱針，精緻的J型唱臂，並內建可切換的PHONO/LINE前級擴大機，可直接連接到配備有PHONO或LINE等級輸入的立體聲音響。

AT-LP5 直驅式唱盤具有以下特色：

- 可更換唱針的Audio-Technica AT95EX Dual Moving Magnet 立體聲唱頭
- 含橡膠墊的鋁製唱片轉盤
- 內建切換式立體聲前級擴大機
- 立體聲RCA類比輸出
- J型唱臂總成，包含：
 - 可調整的重錘
 - 抗滑調整
 - 唱臂升起與上升桿採液壓式動作
 - 含鎖定機制的唱臂座
- USB輸出—無須特殊驅動程式即可於您的電腦使用
- 直接驅動高扭矩馬達
- 可選擇的33/45轉轉速
- 可調整水平的腳座
- 帶有螺絲的絞鏈固定點，用於隨附之可移除式絞鏈防塵蓋

為發揮本產品的最大效用，請仔細閱讀產品說明並遵照本手冊指引操作。請妥善保管本手冊，以備日後參考。建議妥善保存所有包裝材料，以備日後儲存、搬運或運送之用。

注意：為避免唱針損壞，請確保在安裝、搬運或清潔唱盤期間已先妥善裝好唱針護蓋。

安全說明

1. 請閱讀這些說明。
2. 請保存這些說明。
3. 請遵循所有警告。
4. 請遵循所有說明。
5. 請勿在靠近水的地方使用本裝置。
6. 請僅使用乾布清潔。
7. 請勿阻擋任何通風開口處。請依照製造商的說明進行安裝。
8. 請勿安裝在任何熱源處（例如，電暖爐、排氣孔、烤爐），或其他會產生高溫的裝置（包括擴大機）附近。
9. 為確保安全，請勿破壞極性與接地插頭。極性插頭有兩個極片，其中一片較寬。接地插頭除了有兩個極片之外，還有第三個接地棒。較寬的極片與接地棒是為保障您安全的設計，若本裝置插頭與您的插座不相符，請諮詢電工將不適用之插座更換為新式插座。
10. 請保護電源線，不要在電源線上行走或穿刺電線，尤其要特別保護插頭、插座以及與裝置連接的地方。
11. 請僅使用製造商所規定的附件/配件。
12. 請僅使用合格的，或與本裝置一起搭售之推車、立架、三腳架、托架或桌子。使用推車移動裝置時請特別注意，以免傾倒而造成事故。
13. 在有閃電的暴風雨期間，或者長時間不使用時，請拔除裝置插頭。



14. 僅能由合格維修人員進行任何形式之維修。當本裝置發生任何形式損壞，例如電源線或插頭損壞、遭到液體潑灑、異物掉落到裝置中，裝置被雨淋濕或有濕氣、無法正常操作、或摔落地面時，請聯絡合格維修人員進行維修。
15. 若將電源插頭作為斷路裝置使用，則此斷路裝置須維持隨時可操作之狀態。
16. 請將機器放置在通風良好的環境下。
17. 不要讓本裝置暴露到水滴或潑灑到液體，且裝置上不得放置裝滿液體的物體，例如，花瓶。

警告：請勿讓本裝置淋雨或處於濕氣下，以免起火或觸電。不要讓本裝置暴露在水滴或潑灑到液體，且裝置上不得放置裝滿液體的物體，例如，花瓶。



注意
有觸電風險
請勿開啟



注意：請勿讓本裝置淋雨或處於濕氣下，以免起火或觸電。不要讓本裝置暴露在水滴或潑灑到液體，且裝置上不得放置裝滿液體的物體，例如，花瓶。



等邊三角形內帶有箭頭的閃電符號用於警告使用者，在電器機殼內可能存在未絕緣的「危險電壓」，其強度可能足以造成觸電。



等邊三角形內的驚嘆號用於警告使用者，本裝置隨附的文件中包含操作與維護（維修）本裝置的重要說明。

注意：為避免觸電，除非極片可完全插入且不會外露，否則請勿在延長線、插孔或其他插座上使用。

主要功能

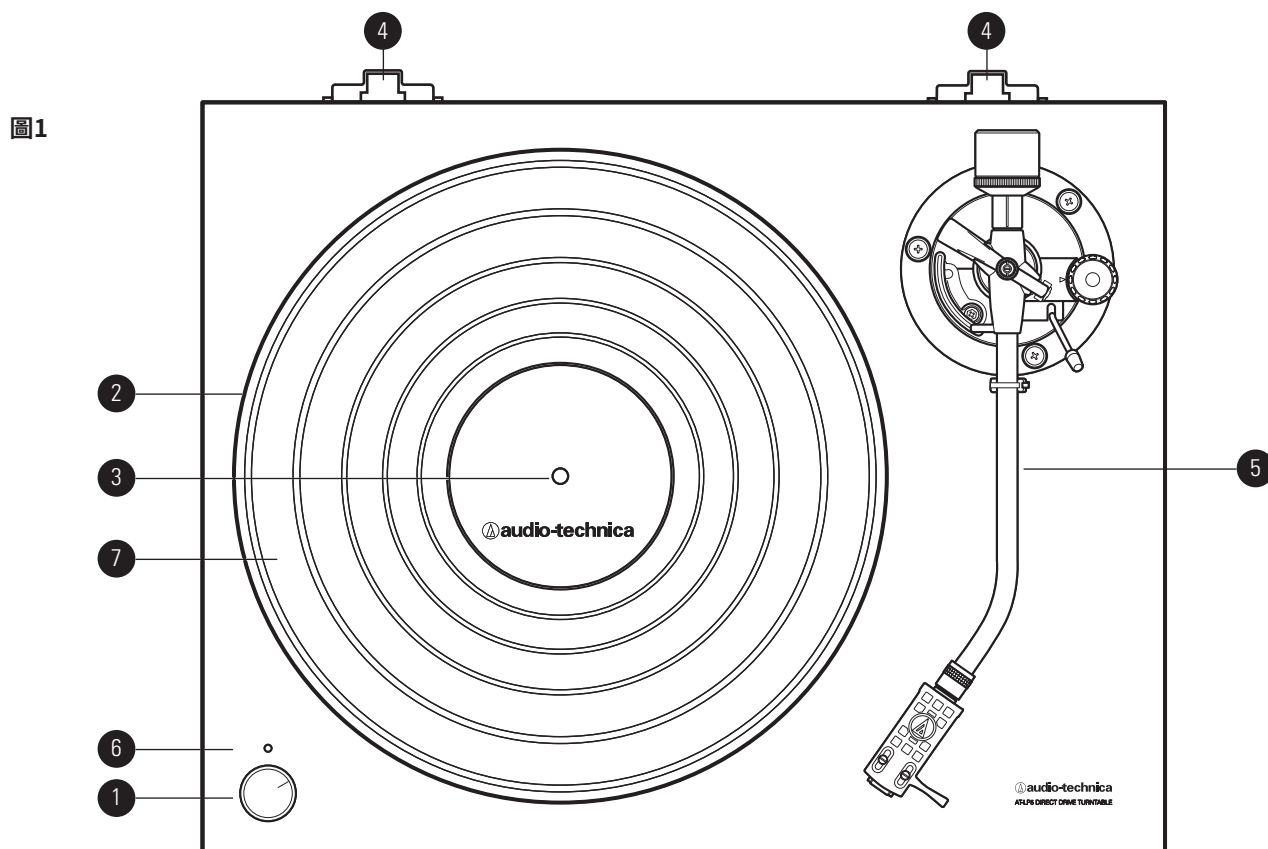

① 33轉/停止/45轉 待機與轉速選擇旋鈕
可選擇33或45轉轉盤轉速與啟動/停止馬達。

② 轉盤
直接安裝在中心轉軸／馬達轉軸上的鋁製轉盤。

③ 中心轉軸
用來帶動轉盤的精密加工轉軸。

④ 防塵蓋鉸鏈座
可拆鉸鏈式防塵蓋的接點。

⑤ 唱臂總成
請參閱第10頁的圖2以獲得詳細資訊。

⑥ 開/關指示燈

⑦ 橡膠墊

唱臂組合圖

圖2

- ⑧ 唱頭蓋與唱頭
 高效能的獨家AT95EX唱頭已固定在唱頭蓋上。
 AT-HS10輕量化唱頭蓋能與J型唱臂完美吻合。
- ⑨ 唱頭蓋鎖定環
 請以逆時鐘方向(朝左)旋轉，以穩固地將插入的唱頭蓋安裝到位，並進入鎖定位置。順時針向右旋轉一圈，則可卸下唱頭蓋。
- ⑩ 唱臂
 幾何造型的J型唱臂，可有效降低循軌錯誤。
- ⑪ 唱臂升起
 可將唱臂自唱片表面升起。
- ⑫ 含鎖定夾的唱臂座
 鎖定夾可用於在搬運期間固定唱臂。
- ⑬ 唱臂升起調整螺絲
 可用於設定唱臂上升幅度。
- ⑭ 唱臂上升控制桿
 可控制唱臂上升的動作。(備註：上升機制採用液壓式設計以減緩唱臂下降速度。)
- ⑮ 抗滑控制
 可對唱臂施加少量的向外力，以抵銷唱片轉動時，唱臂朝唱片中央處往內移動的傾向。
- ⑯ 重錘
 用於平衡唱臂，以及提供與調整唱針適當的針壓。

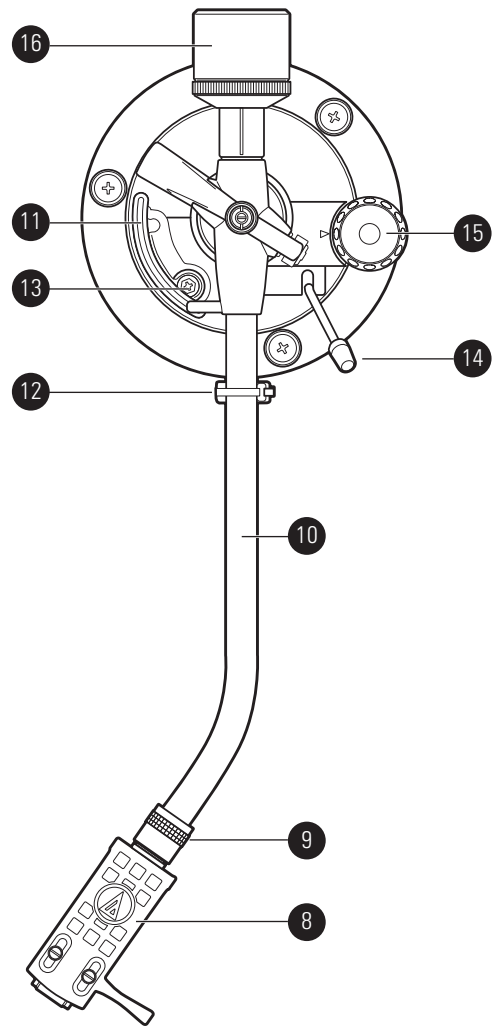

後視圖

圖3

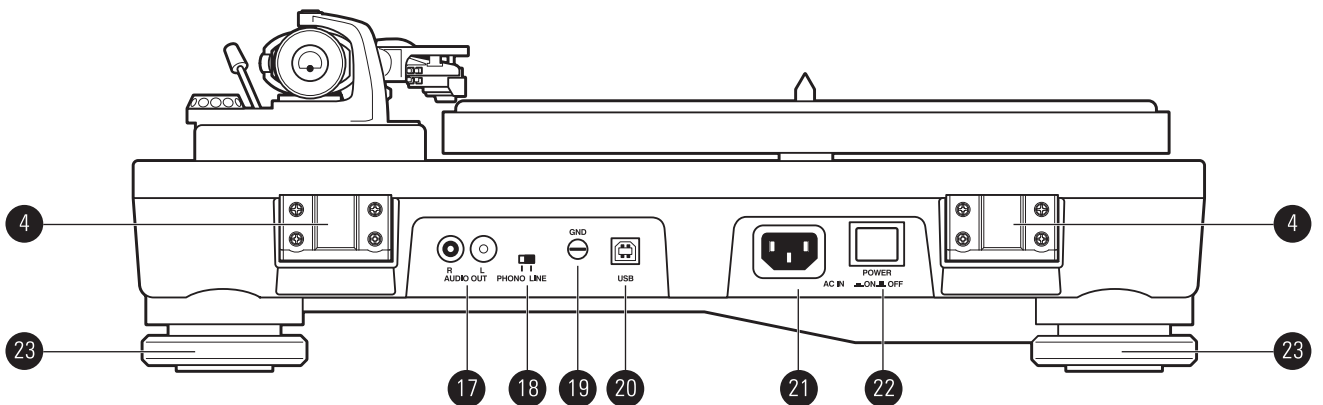

- ⑭ RCA立體聲類比輸出
 使用此端子，連接搭配隨附接地線使用之RCA立體聲導線，將訊號輸入至擴大機的PHONO或LINE端子。
- ⑮ 前級擴大機切換鈕
 搭配有磁性PHONO輸入的擴大機使用本唱盤時，可允許繞過內建立體聲PHONO前級擴大機。
- ⑯ 接地端子
 使用此接地端子連接RCA導線的接地。
- ⑰ USB輸出
 使用此輸出端子將唱盤連接到您電腦的USB輸入埠。
- ⑱ AC電源插座
 連接本機隨附的電源線。
- ⑲ 開/關
 使用此開關來開啟/關閉唱盤電源。
- ⑳ 可調整水平的腳座
 旋轉腳座可調整水平。

初次組裝

打開包裝

請小心打開唱盤包裝，並檢查是否包含以下部件且無缺損：

- 橡膠墊
- 防塵蓋 (位於唱盤上方)
- 轉盤 (位於唱盤下方)
- 重錘 (配件部分)
- 預先安裝於AT-HS10唱頭蓋之AT95EX VM型立體聲唱頭 (配件部分)
- AT-HS10獨家輕量化唱頭蓋
- 電源線
- USB纜線
- 雙RCA公對公導線，包含接地線
- Audacity軟體 (CD)

我們建議妥善保存包裝材料，以備日後儲存、搬遷或運送之用。

唱盤組裝

使用AT-LP5前須進行簡單的組裝。

重要資訊：完成組裝前，請勿連接AC電源線。

設定前級擴大機切換鈕

為提高使用彈性，本製品內建立體聲唱盤前級擴大機。前級擴大機切換鈕位於唱盤的後面板[請參閱圖3、第10頁，編號18]，可讓您選擇內部立體聲前級擴大機「LINE」，或者繞過前級擴大機「PHONO OUT」，以搭配具有專門磁性PHONO輸入插槽的系統使用。音訊輸出導線的紅色RCA類型插頭為右聲道；而白色插頭為左聲道。

如果您所使用的系統具有PHONO輸入，請將前級擴大機切換鈕設定到「PHONO」位置，並連接唱盤的輸出導線到您系統上的PHONO輸入，然後注意紅色為右聲道，白色為左聲道，此外還請使用接地線，連結立體聲RCA導線至接地端子。

如果您的系統沒有PHONO輸入，請將前級擴大機切換鈕設定到「LINE」，並連接唱盤的輸出到「輔助」(AUX) 或您系統上的其他高電平輸入，並注意紅色為右聲道，白色為左聲道。

搭配電腦音效卡使用唱盤時，請設定為「LINE」並連接唱盤的立體聲輸出到電腦音效卡上的音訊LINE輸入。注意：可能需要額外的轉接器(另售)才能將唱盤的雙RCA輸出(左 + 右)連接至電腦音效卡輸入介面。

唱臂組裝

1. 請移除用於在搬運期間固定唱臂的尼龍繩。請使用鎖定夾，暫時將唱臂固定在唱臂座。[圖2，第10頁，編號12]。
2. 將唱頭蓋/唱頭總成插入位於唱臂[請參見圖4]前方的插槽即可完成連接。建議手持唱頭蓋總成的左右邊緣進行安裝，可降低損壞唱針，或阻礙唱頭電線的可能性。

圖4 - 包含固定唱頭的唱頭蓋

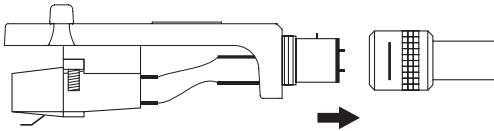

3. 將唱頭蓋插入正確位置後，以逆時鐘方向(朝左)旋轉以固定唱頭蓋至鎖定位置(鎖定狀態下向右旋轉一圈，即可退出唱頭蓋)。
4. 將黑色轉盤往前推並施以旋轉，以帶動調整連接於唱臂後方之重錘[圖2，第10頁，編號16]；重錘將在唱臂後方部位旋轉往前移動。

組裝唱盤轉盤與橡膠墊

1. 將唱盤的轉盤小心置於中心轉軸上，並確保轉盤已完全固定在轉軸上。
2. 將橡膠墊放置在轉盤頂部。

組裝防塵蓋

1. 將防塵蓋絞鍊的T型頭對準位於唱盤機殼後方左右兩側的接口。完成安裝後，防塵蓋絞鍊的平面部位開啟時應與唱盤表面成約45°角。
2. 握住唱盤防塵蓋，小心引導防塵蓋絞鍊到位於防塵蓋後方的兩個插槽內。如果需要的話，絞鍊內的彈簧可讓防塵蓋保持約45°的開啟角度。(注意：只有一個「開口」位置；絞鍊並無法讓防塵蓋「豎立」。)
3. 要從唱盤移除防塵蓋，請從防塵蓋內的插槽輕輕地鬆脫絞鍊。當防塵蓋處於「關閉」位置時，比較容易進行此操作。請小心、緩慢地上升防塵蓋，直到離開主機。之後，如果需要，可從唱盤移除絞鍊。

設定唱臂平衡與針壓

為確保唱頭能適當地播放唱盤上的聲軌，必須小心根據唱頭製造商的規格來設定唱臂平衡與針壓。若未能適當設定，唱臂組件可能會對唱頭的唱針及/或唱片造成損壞。

注意：當移除唱針保護蓋，且釋放了唱臂鎖定夾後，**請特別注意不要損壞唱針**。切勿讓唱針在橡膠墊上拖曳以免刮傷橡膠墊或唱盤。

唱臂設定

1. 請將抗滑調整設定為「0」。[圖2，第10頁，編號15]。
2. 移除透明的唱針保護蓋，小心地往前滑動它，直到離開唱頭的前方。
3. 繼續小心地握住唱頭蓋總成以穩定唱臂，然後釋放唱臂鎖定夾。此時，唱臂已經失去平衡且可自由擺動。
4. 繼續輕輕握住唱頭蓋，小心地旋轉重錘，直到唱臂獲得水平平衡，且能自由地在轉盤上方浮動，且唱頭不會接觸到轉盤表面。
5. 將唱臂鎖回唱臂座。
6. 穩定地握著重錘，但不要做任何轉動，小心旋轉黑色針壓調整環(此可獨立於重錘旋轉)，直到針壓環上的「0」與後唱臂頂部所標示的中心線對準。
7. 請參閱唱頭製造商的規格以獲得推薦的針壓。以逆時鐘方向旋轉整個重錘，且不接觸黑色的針壓環，往前移動重錘，直到針壓環上的所需的值與後唱臂所標示的中心線對準。請參閱唱盤隨附的唱頭針壓值一節的規格，一般而言，AT95EX之針壓為2 g。

初次組裝 (續)

設定抗滑

為了補償唱片旋轉時從中心部位將唱臂往內拉的「滑動」力道，可以施加少量的朝外「抗滑」力道給唱臂。為了在正常唱盤使用情況下獲得最好的效能，請將抗滑控制鈕[圖2，第10頁，編號15]設定為與針壓轉盤相同的設定。請參閱唱盤隨附的唱頭針壓值一節的規格。

類比音訊連接

根據前級擴大機切換鈕的設定，連接音訊輸出導線到您擴大機、接收器、主動式喇叭、音效卡或其他裝置的適當的輸入插座。

將數位音訊USB連接到含USB輸入的電腦

可使用USB導線（隨附）連接AT-LP5唱盤到您的電腦，而無須使用特殊的驅動程式。

為了方便您使用，您的Audio-Technica AT-LP5唱盤有提供Audacity錄音軟體。請注意，其他第三方套裝軟體也與本唱盤相容。

Audacity

Audacity是一套根據GNU一般公共授權(GPL)下流通的免費軟體。隨附的Audacity CD與Audacity網站上有提供更多資訊與開放原始程式碼：

<http://audacity.sourceforge.net>

***使用USB輸出時，請務必將AT-LP5唱盤的前級擴大機切換鈕設定到「LINE」位置（該開關位於唱盤的後方）。**

最後，當完成所有音訊連接後，請將隨附的AC電源線連接到唱盤。之後，再連接電源線插頭到AC插座。

為獲得最佳效果，請勿將本機安裝在有高溫、濕氣、灰塵或強烈震動的地方，並避免在這些地方操作。

準備播放

1. 移除唱頭上的唱針護蓋，然後解除鎖定唱臂座（如果有鎖定的話）。
2. 在橡膠墊上放置一張唱片，使其中心孔對準中心轉軸。如果是45轉唱片，請在轉盤放置唱片前，先在中心轉軸上放置45轉轉接器。

播放唱片

1. 按下後面板上的電源按鈕以開機。
2. 將轉盤旋轉速度(33/45)設定為符合唱片的速度，轉盤即會開始旋轉。
3. 升高唱臂控制桿，以上升唱臂到「UP」位置。
4. 將唱臂放置在唱片播放所需的位置（溝槽）上。
5. 移動唱臂控制桿，以下降唱臂到「DOWN」位置。唱臂會緩慢下降到唱片後開始播放。

-或者-（跳過 2 - 3 - 4）

使用唱頭蓋總成上的手指托架，將唱臂移動到唱片上播放所需的位置。小心下降唱臂到唱片表面。

暫停或結束播放

1. 若要暫停播放，請使用唱臂上升控制桿來升起唱臂。
2. 播放結束後，請上升唱臂上升控制桿，然後移動唱臂到唱臂座後，並使用唱臂鎖定夾來固定唱臂。
3. 旋轉轉速選擇器到「停止」的位置，以使轉盤停止旋轉。
4. 按下後面板上的電源按鈕以關機。

安裝新唱頭

機械裝配

1. 打開唱頭包裝，安裝前請先小心移除唱針組件，以不會造成損傷的方式放置唱針組件。接著將新唱頭固定至唱頭蓋組件。請使用新唱頭隨附的工具進行固定，以適當力道鎖緊固定螺絲。先簡略裝上唱針組件，以檢查結構上是否已正確安裝。唱針組件正確安裝時，應有喀嚓一聲卡入到位。請確認新唱頭已依製造商說明安裝於唱頭蓋組件。確認正確安裝後，您可再次移除唱針組件以妥善保存。

電力連接

1. 位於唱頭後方的四個端子使用顏色編碼，以符合立體聲唱臂的標準配線。請使用唱頭蓋配線所提供的扣夾。切勿焊接唱頭端子！對端子加熱將損壞內部唱頭配線。
2. 最後，請將唱針輕壓入唱頭本體，並小心不要損壞唱針。唱針組件正確安裝時應會發出喀嚓一聲卡入到位。接著將唱頭蓋組件安裝至唱臂，並小心不要損壞唱針組件。
(注意：更換過唱頭後，請根據唱頭的規格重設唱臂平衡、針壓與抗滑設定。)

使用MC型(動圈)唱頭

1. 請注意，內建的前級擴大具有36dB的增益，輸入阻抗則為47k歐姆，僅能搭配VM型(動磁)唱頭使用，例如隨附的AT95EX。使用MC型唱頭時，必須將前級擴大設定為PHONO以跳過內建前級擴大機(圖3、第10頁，編號18)，在此情況下，唱盤的輸出必須連接至支援MC型唱頭輸入的外部前級擴大機，才能確保在使用MC型唱頭(請參閱您MC唱頭的規格)時獲得適當的增益與阻抗匹配。

故障排除

唱盤正常運作但無法發出聲音或音量很低。

1. 擴大機（系統）控制設定不正確：選擇了錯誤的輸入、卡帶監視器開啟、揚聲器關閉等。請檢查適當的控制設定。
2. 唱針斷裂或遺失。請檢查唱頭，若有必要請更換。
3. 唱針組件可能未正確安裝於唱頭本體。請檢查唱頭，若有必要請進行調整。
4. AT-LP5的前級擴大機切換鈕設定到錯誤的位置。請檢查已設定到正確的輸出以符合擴大機輸出。
 - 沒有聲音/聲音非常微弱：PHONO輸出設定為輔助/LINE輸入。
 - 聲音非常大/嚴重失真：LINE輸出設定到PHONO輸入。
5. 針壓設定太重（唱頭已經接觸到唱片）。請依唱頭製造商的建議，設定合適的針壓。
6. 唱盤受到來自地板、牆壁或周圍揚聲器的過量震動影響。請降低震動，或將唱盤放置在穩定/穩固的表面。

唱盤正確運作，但唱針會在唱片上「跳針」。

1. 唱針護蓋仍未取下。請移除唱針護蓋。
2. 針壓不足。請依唱頭製造商的建議值設定針壓。
3. 沒有適當設定抗滑控制。請檢查是否有依唱頭針壓完成抗滑設定。

唱片聲音太快或太慢。

1. 唱盤的轉速設定錯誤。請根據所播放的唱片類型，以轉盤速度選擇器設定適當的轉速。

避免損壞的提示

- 切勿用您的手指觸摸唱針尖端；請勿讓唱針撞擊唱盤護墊或唱片邊緣。
- 請經常清理唱針尖端，僅可使用軟毛刷子以**由後往前移動**的方式清理。
- 使用唱針清潔液時，請**少量使用**即可。
- **切勿**在唱盤系統任何部位使用強力化學物品或溶劑。
- 在移動唱盤之前，務必將插頭從AC插座上拔掉，並**將唱臂固定在唱臂座上**。

規格*

唱盤規格

| | |
|------------------|------------------------------------|
| 類型 | 2段轉速，全手動操作 |
| 馬達 | DC馬達 |
| 驅動方法 | 直驅式 |
| 轉速 | 33-1/3 RPM、45 RPM |
| 唱盤轉盤 | 鑄鋁 |
| 啟動力矩 | >1.6 kgf.cm |
| 制動系統 | 電子式制動 |
| 顫動誤差 | < 0.2% WRMS (33 RPM) |
| 訊噪比 | > 50 dB |
| 輸出電壓 | |
| 「PHONO」（跳過前級擴大機） | 4 mV額定，1 kHz，5 cm/sec |
| 「LINE」（使用前級擴大機） | 150 mV額定，1 kHz，5 cm/sec |
| PHONO前級擴大機增益 | 36 dB額定，RIAA等化 |
| USB功能 | |
| A/D、D/A | 16bit 44.1 或 48kHz USB可切換 |
| 電腦介面 | USB 2.0相容，Windows XP、Vista或MAC OSX |

唱臂規格

| | |
|----------------------|----------|
| 類型 | 靜態平衡J型唱臂 |
| 有效長度 | 247 mm |
| 超距 | 17 mm |
| 最高循軌誤差角度 | 小於2.5° |
| 唱針壓力調整範圍 | 0至2.5 g |
| 適用的唱頭重量範圍 (包含唱頭蓋) | 15至20 g |

唱頭與唱頭蓋規格

| | |
|---------|--------------------------|
| 唱頭型號 | AT95EX |
| 唱頭類型 | VM型立體聲Dual Moving Magnet |
| 建議的阻抗匹配 | 47,000歐姆 |
| 輸出電壓 | 4 mV (1 kHz, 5 cm/sec) |
| 唱針 | 0.3 x 0.7 mil, 橢圓唱針 |
| 針壓範圍 | 1.5至2.5 g (標準2 g) |
| 唱頭重量 | (AT95Ex) 5.7 g |
| 唱頭蓋型號 | AT-HS10 |
| 唱頭蓋重量 | 10 g |
| 唱頭蓋超距調整 | ± 5 mm |

一般規格

| | |
|--------|--|
| 電源供應要求 | 230V AC, 50 Hz (新加坡) 110V AC, 60 Hz (台灣) |
| 電力消耗 | 6 W |
| 外形尺寸 | 450.0 mm W x 352.0 mm D x 157.0 mm H |
| 重量 | 8.5 kg |
| 包含配件 | AT95EX Dual Moving Magnet 立體聲唱頭，含可更換的唱針；獨家AT-HS10輕量化唱頭蓋；AC電源線；雙RCA (公) 至雙RCA (公) 立體聲導線；45轉轉接器；USB導線；錄音軟體 |

Audacity：

| | |
|------|---|
| 系統需求 | 配有支援USB2.0連接埠之電腦主機(PC或Mac) 執行OS X 10.4至10.10的Mac， 或者執行Windows (XP與更新版本) 的PC |
| 安裝 | 可燒錄CD與進行軟體安裝的CD-R 或CD-RW 光碟機 內含PC & Mac使用者的Audacity 軟體 |

*規格若有變動，恕不另行通知。

MEMO

A series of horizontal dotted lines for writing.



Audio-Technica Corp.

2-46-1 Nishi-naruse, Machida, Tokyo 194-8666, Japan

©2016 Audio-Technica Corp.

中国大陆客户联系资料

代理商: 广州市德讯贸易有限公司
地址: 广州市越秀区中山二路31号鸿瑞大厦908室
电话: +86 (0)20 - 37619291
生产标准: GB8898-2011, GB13837-2012
原产地: 中国深圳市 出版日期: 2016年 3月

香港及澳門地區客戶聯絡資料

總代理: 鐵三角(大中華)有限公司
地址: 香港九龍紅磡民裕街51號凱旋工商中心第二期9樓K室
電話: +852 - 23569268

台灣地區客戶聯絡資料

進口廠商: 台灣鐵三角股份有限公司
地址: 32050 桃園市中壢區過嶺里福達路二段322巷6號
服務專線: 0800 - 774488
原產地: 中國深圳市